

Sundance[®] Spas

HOW TO MAKE
DELIVERY AND
INSTALLATION OF
YOUR NEW HOT
TUB FAST, EASY
AND TROUBLE-FREE



P R E • D E L I V E R Y

G U I D E

IMPORTANT SERVICE INFORMATION

Please make a record of the following information.
It will be valuable if service is required.

HOT TUB MODEL

COVER TYPE

HOT TUB SERIAL NUMBER

DATE PURCHASED

DATE INSTALLED

HOT TUB DEALER'S ADDRESS

HOT TUB DEALER'S PHONE NUMBER

Most cities and counties require permits for exterior construction and electrical circuits. In addition, some communities have codes requiring residential barriers such as fencing and/or self-closing gates on the property to prevent unsupervised access to a pool or hot tub by children under five years of age. Your Sundance Spas dealer can provide information on which permits may be required and how to obtain them prior to delivery of your hot tub.

INTRODUCTION

CONGRATULATIONS!

You've purchased a Sundance spa, made to exacting ISO 9001 quality standards. With a little preparation and care, your hot tub will give you many years of enjoyment. This booklet has been designed to provide you with all the information you'll need to ensure a safe, speedy and trouble-free hot tub delivery and installation.

Please read this booklet before your scheduled delivery.



TABLE OF CONTENTS

Important service information	1
Introduction	2
Planning the best location for your hot tub	3
Preparing a good foundation	5
Getting the hot tub into your yard	7
Electrical requirements	9
Common house to hot tub connection diagrams:	
3-Wire 240 VAC powered models	11
3-Wire 120 VAC powered models	12
4-Wire 240/120 VAC powered models	13
Electrical installation: 3-Wire 240 VAC models	14
Electrical installation: 3-Wire 120 VAC or 4-Wire 240/120 VAC models	16
Power supply requirements	18
Hot tub technical specifications	24

PLANNING THE BEST LOCATION FOR YOUR HOT TUB

Here are some of the things you will need to consider when determining where to place your new hot tub.

S A F E T Y F I R S T

Do not place your hot tub within 10 feet of overhead power lines.

Make sure your hot tub is positioned so that access to the equipment compartment and side panels will not be blocked. Be certain that your installation will meet all city and local safety codes and requirements.

H O W W I L L Y O U U S E Y O U R H O T T U B ?

How you intend to use your hot tub will help you determine where you should position it. For example, will you use it more for recreational or therapeutic purposes? If your hot tub is mainly for family recreation, be sure to leave plenty of room around it for activity and lawn furniture. If you will use it more for relaxation and therapy, you'll probably want to create a specific mood around the tub.

E N V I R O N M E N T

If you live in a climate with a snowy winter and hot summer, a place to change clothes or house entry near the hot tub is convenient.

A warmer climate may require shade from the hot sun. Consider placement of trees, shrubs, patio cover or perhaps a gazebo structure to provide what you'll need.

Indoor installations require adequate ventilation. When the hot tub is in use, considerable amounts of moisture are produced. This moisture can damage walls and ceiling surfaces over time. Special paint is available to resist moisture damage. Remember that hot tubs periodically require drainage, so plan your environment accordingly.

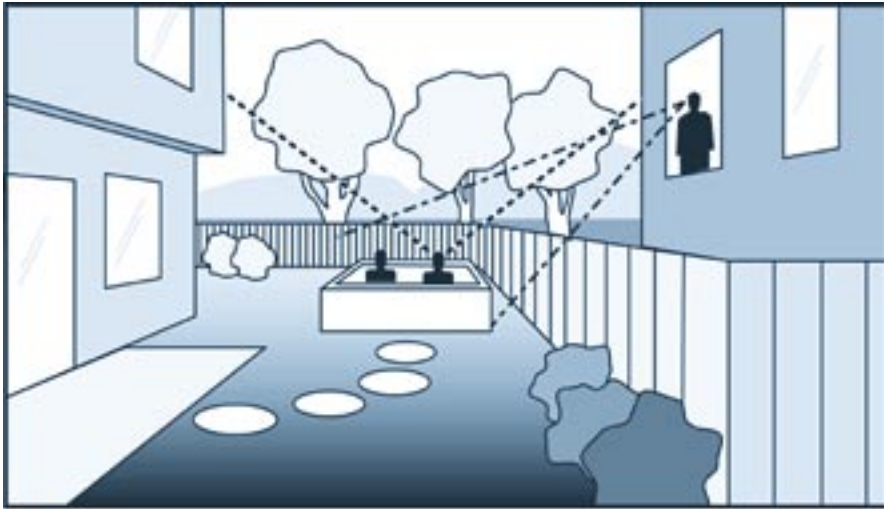

Proper planning will enhance your enjoyment of the hot tub experience and protect your privacy.

CONSIDER YOUR PRIVACY

In a cold-weather climate, bare trees in winter won't provide much privacy. Think of your surroundings during all seasons to determine your best privacy options. Consider the view of your neighbors as well, when you plan the location of your hot tub.

PROVIDE A VIEW WITH YOUR HOT TUB

Think about the direction you will be facing when sitting in your hot tub. Do you have a special landscaped area in your yard that you find enjoyable? Perhaps there is an area that catches a soothing breeze during the day or a lovely sunset in the evening. Consider these things when you plan your location.

KEEP YOUR HOT TUB CLEAN

Prevent dirt and foliage from being tracked into your hot tub by utilizing concrete for paths and access areas. Check the location of trees and spill paths from gutters to see if wind or rain will sweep debris into your tub.

ALLOW FOR SERVICE ACCESS

Many people choose to install tile or custom wood around their hot tubs. If you're installing your tub with custom decorative trimming, remember to allow for access to it for service. Should you need service, a technician may need to remove the tub's side panels, or access it from beneath. It's always best to design special installations so that the tub can still be moved, or lifted from the ground.

PREPARING A GOOD FOUNDATION

Your hot tub needs a good solid foundation. The area that your hot tub sits on must be able to support the weight of the tub, the water in it and those who use it. If the foundation is inadequate, it may shift or settle after the hot tub is in place, causing stress to the shell.

NOTE :

Damage caused by inadequate or improper foundation support is not covered by the hot tub warranty. It is the responsibility of the hot tub owner to provide a proper foundation for the hot tub.

Place the hot tub on an elevated foundation so that water drains away from it. Proper drainage will keep components dry from rain and wet weather.

If you are installing your hot tub indoors, pay close attention to the flooring beneath it. Always remember that a hot tub is filled with water. Choose flooring that won't be spoiled or ruined from water damage.

*A hot tub filled with water is heavy. If you are installing it on an elevated wood deck or other structure, it is advisable to consult a structural engineer or contractor to ensure the structure will support the weight. See technical specifications page 24.

*It is strongly recommended that a qualified, licensed contractor prepare the foundation for your hot tub. There is a 4" minimum depth requirement for a concrete pad.

**THESE ARE
RECOMMENDED
FOUNDATIONS**

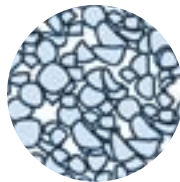

***Concrete Pad
(4" or Thicker)**



***Wood Decking
(with Concrete Foundation)**

YOUR SUNDANCE RETAILER CAN HELP YOU WITH FOUNDATIONS AND MORE.

Your Sundance retailer has a wealth of information and experience about how to get the most out of your Sundance hot tub. Ask your retailer to share the Sundance Idea Book to see creative hot tub decorating and installations from mild to wild. Your Sundance retailer also has a full line of accessories, surround kits, and gazebos that are engineered to compliment your Sundance hot tub.

Preparing a good foundation for your hot tub will ensure years of trouble-free enjoyment.



GETTING THE HOT TUB INTO YOUR YARD

CHECK THE DIMENSIONS OF YOUR HOT TUB

The **Hot Tub Specification chart on page 24** lists your hot tub model and its dimensions as it sits on the delivery cart. During delivery the hot tub must remain on the delivery cart at all times. Compare the hot tub dimensions to the width of gates, sidewalks, and doorways along the delivery route used to bring the hot tub into your yard. It may be necessary for you to remove a gate or partially remove a fence in order to provide an unobstructed passageway to the installation location.

PLAN THE DELIVERY ROUTE

Use the diagram on **page 8** to plan your delivery route.

Consider the following when planning your delivery route:

- Check the width of gates, doors and sidewalks to make sure your hot tub will pass through unobstructed. You may have to remove a gate or part of a fence to allow for adequate width clearance.
- If the delivery route will require a 90° turn, check the measurements at the turn to ensure the hot tub will fit.
- Are there protruding gas meters, water meters or A/C units on your home which will cause obstructions along the delivery path to your yard?
- Are there low roof eaves, overhanging branches or rain gutters that could be an obstruction to overhead clearance?
- Are there more than six (6) consecutive stairs without a landing in your delivery route? If so, you must consult your Sundance dealer prior to delivery to make adequate preparations.

SPECIAL CIRCUMSTANCES

The use of a crane for delivery and installation is necessary about 10% of the time. It is used primarily to avoid injury to your hot tub, your property or to delivery personnel. Your Sundance dealer may be able to assist you with the arrangements. If your hot tub delivery requires the use of a crane, the cost of a crane is generally not included in standard delivery service.

Check overhanging branches.

Check number of stairs. No more than 6 in a row without a landing.

Check corner clearance. Hot Tub will not bend.

Check structures such as dog houses, wood piles, etc.

Check all gates and entries for width clearance.

Check protruding meters, fixtures and rain gutters.

Check overhang clearance.

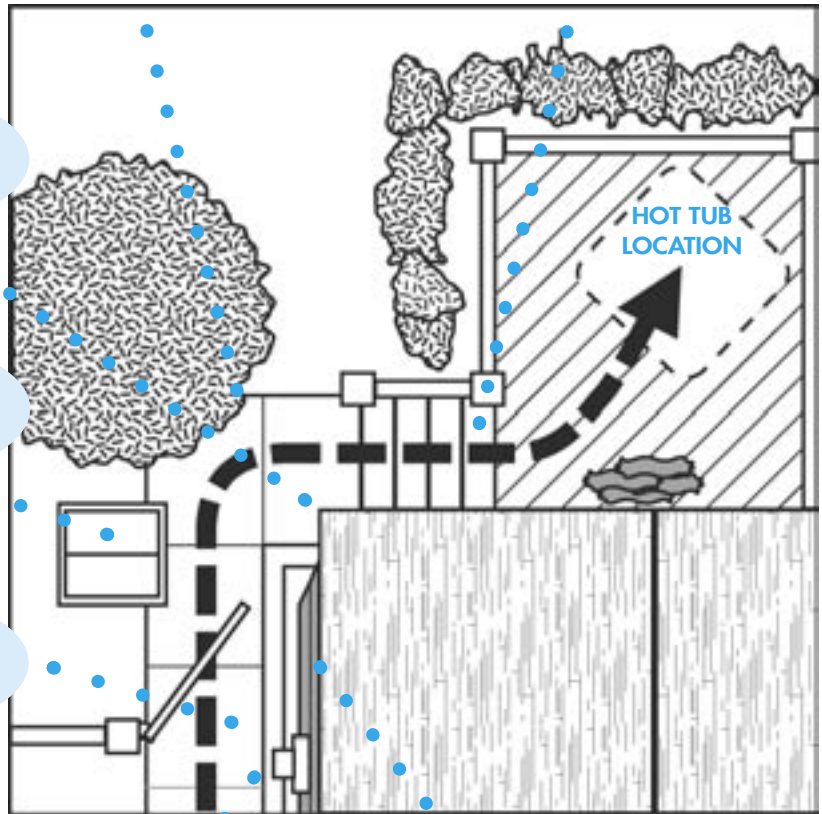

ELECTRICAL REQUIREMENTS

IMPORTANT!

If installed in the United States, the electrical wiring of this hot tub must meet the requirements of the National Electric Code (NEC) and any applicable state or local codes. The electrical circuit must be installed by an electrical contractor and approved by a local building/electrical inspection authority.

ELECTRICAL SETUP BEFORE DELIVERY OF YOUR HOT TUB

- 1 All 240V hot tubs must be permanently connected (hard wired) to the power supply. All 120V powered models (Caprio, Tango, Solo, and Lagunas) must use the provided (15 foot) GFCI cord plugged directly into a **dedicated grounded wall outlet** or must be hard wired. The 15 foot cord refers to its length from the load box to electrical outlet. Actual exposed cord length will vary by model but never be less than 10 feet. **Never lengthen the supplied GFCI cord or use an extension cord with it for any reason!** See page 18-23 for specific power supply requirements by model. Supplying power to the hot tub which is not in accordance with these instructions will void both the independent testing agency's listing and the manufacturer's warranty.
- 2 The power supplied to the hot tub must be a dedicated circuit with no other appliances or lights sharing the power.
- 3 To determine the specific configuration for your hot tub's power connection, refer to Power Supply Requirements on page 18-23.
 - Wire size must be appropriate per NEC and/or local codes.
 - Wire size is determined by length of run from breaker box to spa and maximum current draw.
 - We recommend THHN copper core wire.
 - All wiring must be copper to ensure adequate connections. **Do not use aluminum wire.**
 - When using wire larger than #6, add a junction box near the hot tub and reduce to short lengths of #6 wire between the junction box and the hot tub.

- 4 The electrical supply for the hot tub must include a suitably rated switch or circuit breaker to open all ungrounded supply conductors to comply with Section 422-20 of the National Electric Code, ANSI/NFPA 70. The disconnecting means must be readily accessible to the hot tub's occupant but installed at least 5 feet (1.5 m) from the hot tub water.
- 5 The electrical circuit for the hot tub must include a suitable ground fault circuit interrupter (GFCI) as required by NEC Article 680-42 (See illustrations on the following pages for the proper wiring configuration for your model hot tub).



Diagrams
Illustrate
Standard Wiring
Practices.

SUNDANCE MODELS: Altamar, Cameo, Capri, Caprio ST, Marin, Maxxus, and Optima

SWEETWATER MODELS: Palermo, Bahia, and Cayman

**Note: A pressure sensitive terminal block is provided on the outside surface of the load box to permit connection of a bonding wire between this point and any metal equipment chassis, metal water pipe, or metal conduit within 5 feet (1.5 m) of the hot tub. The bonding wire must be at least #8 AWG (8.4 mm²) solid copper wire. Before installing this hot tub, check with local the local building department to ensure installation conforms to local building codes.

2-Pole Circuit Breaker with 2-Wire Grounded Load Connection
(3 Wires to Hot Tub, 2-Hot (L1-L2), 1-Ground)

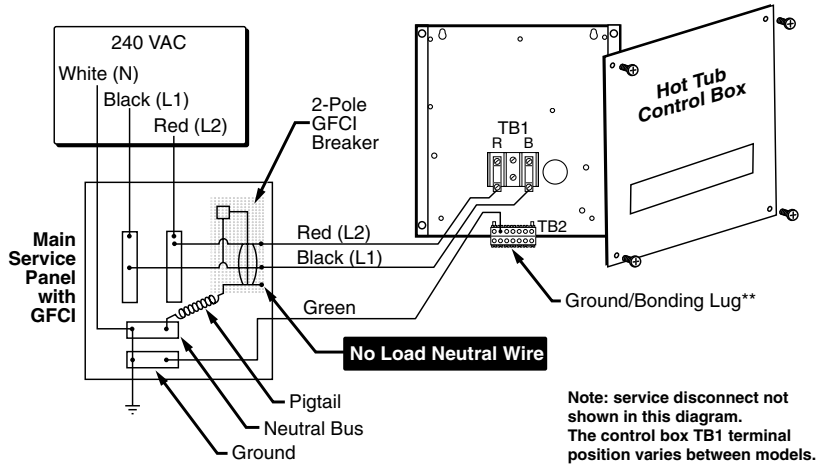

Main Panel with Secondary GFCI Shut-Off Box Using a 2-Pole GFCI Breaker with 2-Wire Grounded Connection
(3 Wires to Hot Tub, 2-Hot (L1-L2), 1-Ground)

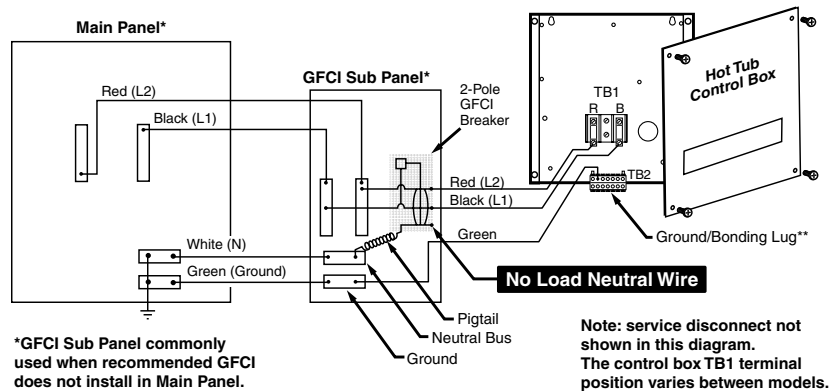

3 - W I R E 1 2 0 V A C M O D E L S

SUNDANCE MODELS: Caprio*, Solo, and Tango (See page 13 for optional 4-wire 240/120 VAC Connection.) *See Page 11 for Caprio ST

SWEETWATER MODELS: Lagunas

1-Pole Circuit Breaker with 3-Wire Grounded Load Connection (3 Wires to Hot Tub, 1-Hot (L), 1-Neutral (N), 1-Ground)

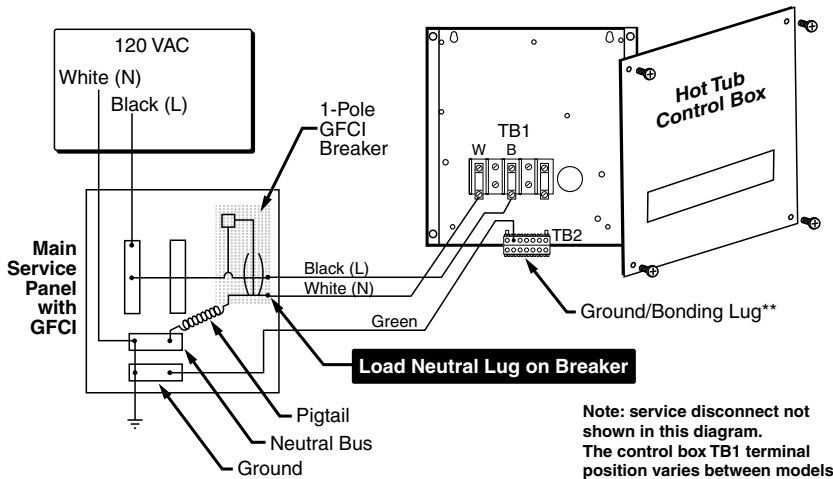

Main Panel with Secondary GFCI Shut-Off Box Using a 1-Pole GFCI Breaker with 3-Wire Grounded Connection (3 Wires to Hot Tub, 1-Hot (L), 1-Neutral (N), 1-Ground)

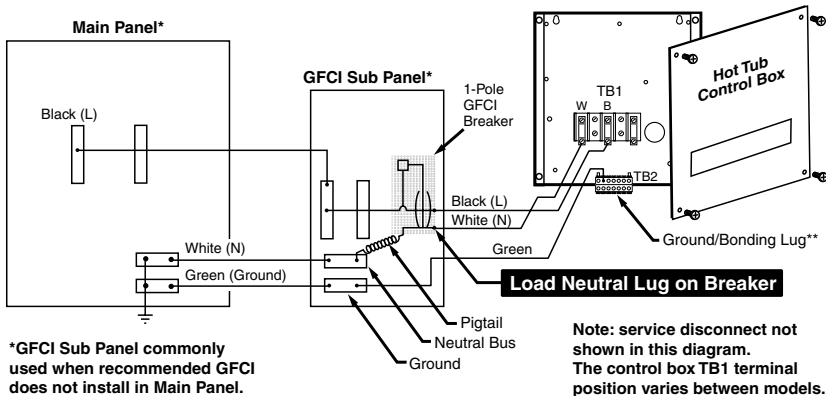

Diagrams illustrate discarding the provided 10 foot GFCI power cord for a 3-wire hard wired connection. This action is necessary when the provided GFCI cord does not reach a dedicated/grounded wall outlet. See page 13 for enhanced heater performance using a 4-wire power connection.

**Note: A pressure sensitive terminal block is provided on the outside surface of the load box to permit connection of a bonding wire between this point and any metal equipment chassis, metal water pipe, or metal conduit within 5 feet (1.5 m) of the hot tub. The bonding wire must be at least #8 AWG (8.4 mm²) solid copper wire. Before installing this hot tub, check with local the local building department to ensure installation conforms to local building codes.

4 - WIRE 240 / 120 VAC MODELS

SUNDANCE MODELS: Caprio*, Tango, and Solo (*See page 11 for Caprio ST Models)

SWEETWATER: Lagunas

2-Pole Circuit Breaker with 3-Wire Grounded Load Connection
(4 Wires to Hot Tub, 2-Hot (L1-L2), 1-Neutral (N), 1-Ground)

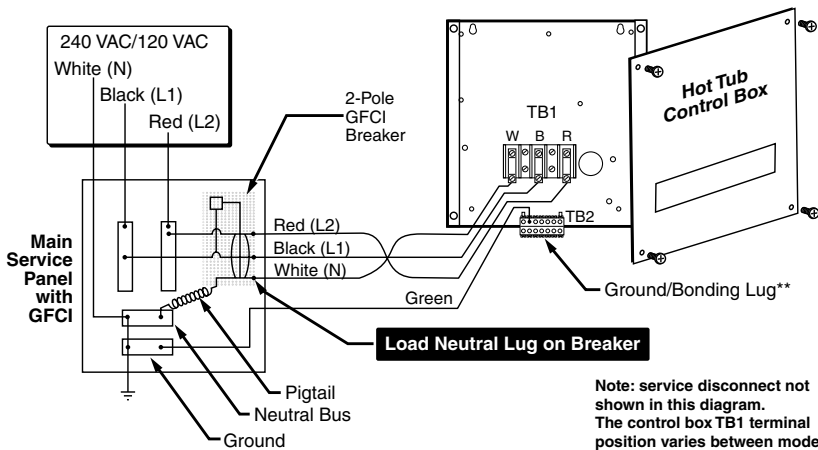

Main Panel with Secondary GFCI Shut-Off Box Using a 2-Pole GFCI Breaker with 3-Wire Grounded Connection
(4 Wires to Hot Tub, 2-Hot (L1-L2), 1-Neutral (N), 1-Ground)

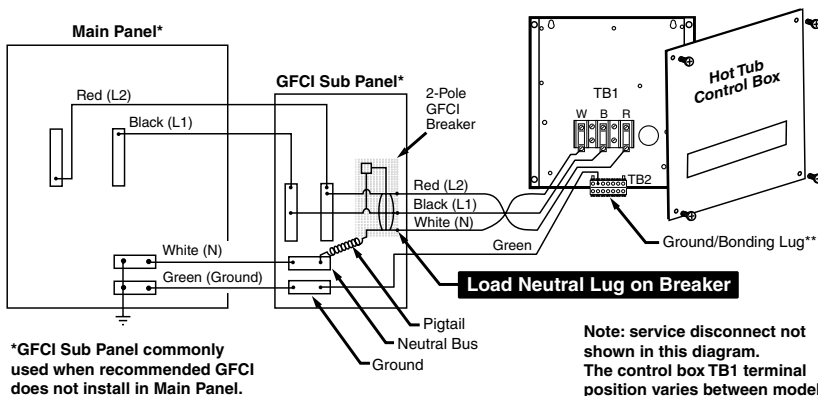

Diagrams illustrate converting the provided 10 foot GFCI power cord to A 4-wire hard wired connection.

This action enhances heater performance over standard 120 VAC 3-wire power connections (see page 12).

**Note: A pressure sensitive terminal block is provided on the outside surface of the load box to permit connection of a bonding wire between this point and any metal equipment chassis, metal water pipe, or metal conduit within 5 feet (1.5 m) of the hot tub. The bonding wire must be at least #8 AWG (8.4 mm²) solid copper wire. Before installing this hot tub, check with local the local building department to ensure installation conforms to local building codes.

ELECTRICAL INSTALLATION OF HOT TUB AFTER DELIVERY

IMPORTANT!

**SAFETY NOTICE FOR 3-WIRE 240 VAC MODELS!
(Refer to page 16 for 3-wire 120 VAC or 4-wire 240/120
VAC powered models)**

Proper grounding is extremely important. A pressure wire connector is provided to permit connection of a bonding wire between the hot tub and any metal within 5 feet of the hot tub. Bonding wire must be at least #8 AWG (8.4 mm²) solid copper wire.

- 1** To gain access to the hot tub's power terminal strip, remove the four screws securing the center wooden cabinet panel on the side of the hot tub under the control panel. After removing the wooden cabinet panel, remove the four control box cover screws.
- 2** Inlets are provided to allow the power supply to enter the equipment area from either side of the hot tub near the base (Illustration 2, page 15). Select the inlet you want to use and remove the narrow cabinet panel from the front of the spa to allow you to feed the cable through to the control box.
- 3** Install the cable with a connector through the large opening provided at the bottom of the control box (Illustration 3, page 15).
- 4** Connect wires, color to color, on the terminal strips (Illustration 4A-4B, page 15) and tighten securely.
- 5** Re-install the control box door and cabinet side panels. Electrical installation is now complete.

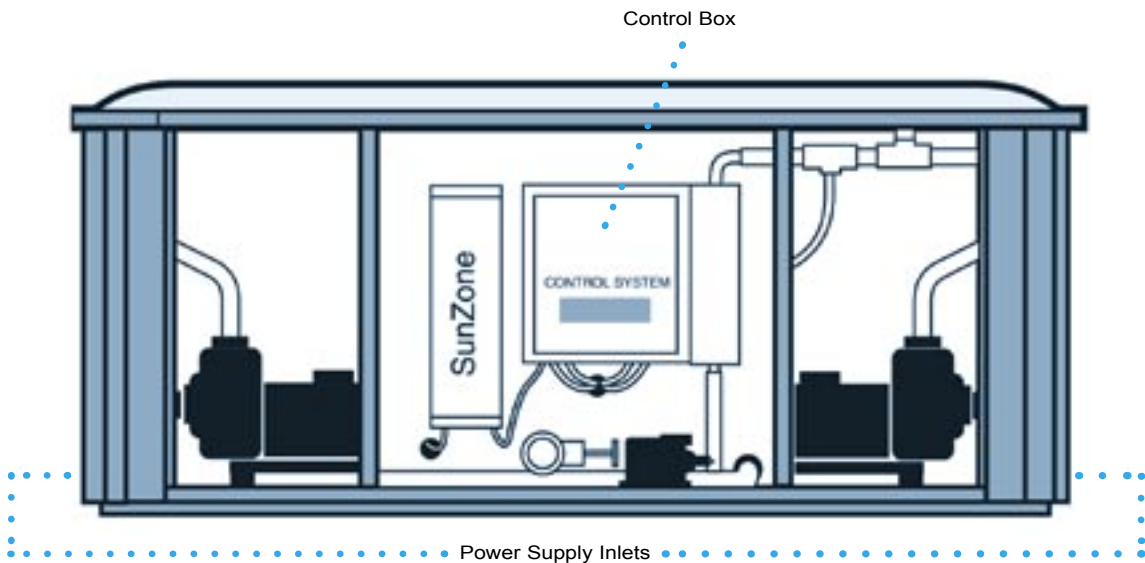
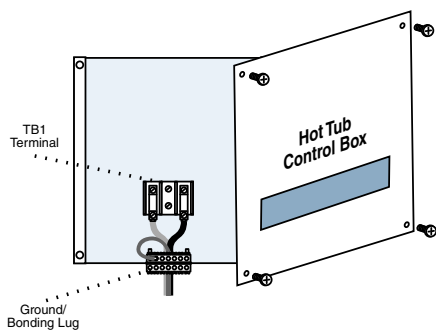

Illustration 2: The hot tub's equipment compartment.

**Illustration 3:
Control Box**



Note: TB1 terminal location will vary between models; 3-wire/240 VAC connection illustrated

**Illustration 4A:
3-Wire/240 VAC Connection**
for Altamar, Cameo, Capri,
Caprio ST, Marin, Maxxus,
and Optima Models.
Hard Wired Connectins Only.

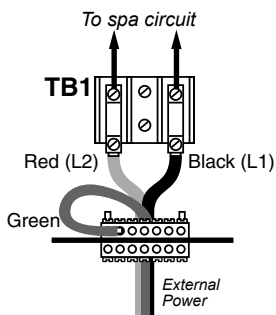

**Illustration 4B:
3-Wire/240 VAC Connection**
for Bahia, Cayman,
and Palermo Models.
Hard Wired Connections Only.

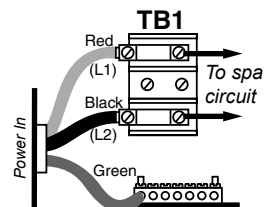

ELECTRICAL INSTALLATION OF HOT TUB AFTER DELIVERY

IMPORTANT!

S A F E T Y N O T I C E F O R 3 - W I R E 1 2 0 V A C O R 4 - W I R E 1 2 0 / 2 4 0 V A C M O D E L S !

(Refer to page 14 for 3-wire 240 VAC Powered Models.)

Proper grounding is extremely important. A pressure wire connector is provided to permit connection of a bonding wire between the hot tub and any metal within 5 feet of the hot tub. Bonding wire must be at least #8 AWG (8.4 mm²) solid copper wire.

- 1** To gain access to the hot tub's power terminal strip, remove the four screws securing the center wooden cabinet panel on the side of the hot tub under the control panel. After removing the wooden cabinet panel, remove the four control box cover screws.
- 2** Inlets are provided to allow the power supply to enter the equipment area from either side of the hot tub near the base (Illustration 2A, page 17). Select the inlet you want to use and remove the short cabinet panel from the front of the hot tub to allow you to feed the cable through to the control box.
- 3** Install the cable with a connector through the large opening provided at the bottom of the control box (Illustration 3A, page 17).
- 4** Connect wires, color to color, on the terminal strips (Illustration 4C-4D, page 17) and tighten securely.
- 5** Reinstall the control box door and cabinet side panels. Electrical installation is now complete.

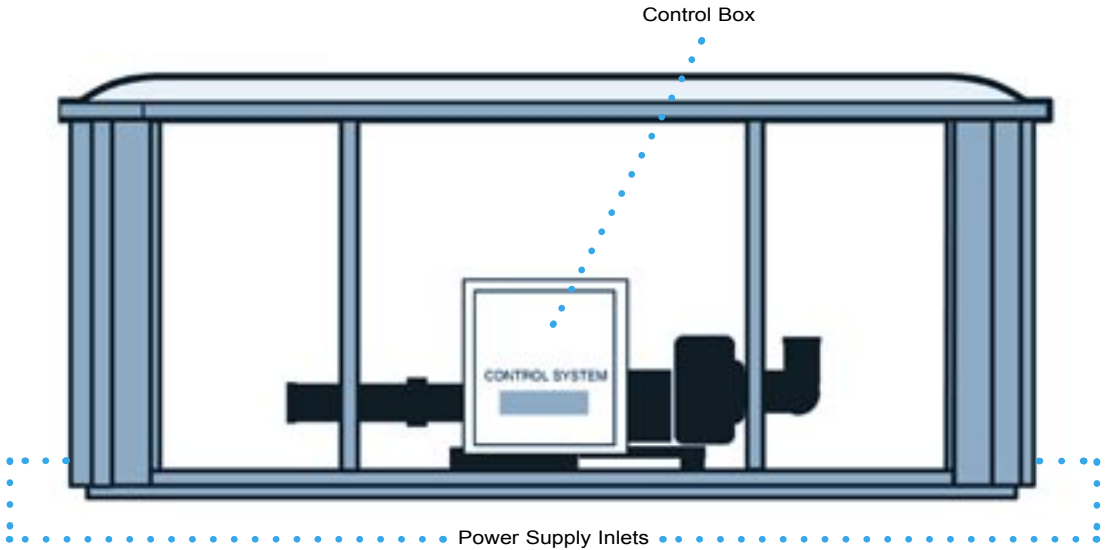
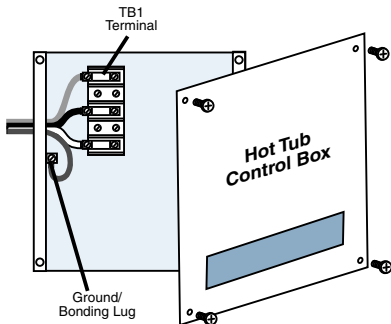

Illustration 2A: The hot tub's equipment compartment.

Illustration 3A:
Control Box



Note: TB1 terminal location will vary between models

Illustration 4C:
Standard 3-wire, 120 VAC
connection for Caprio, Tango,
Solo, and Lagunas models. Use
provided 10' GFCI cord or hard
wire for runs over 10' (3m).

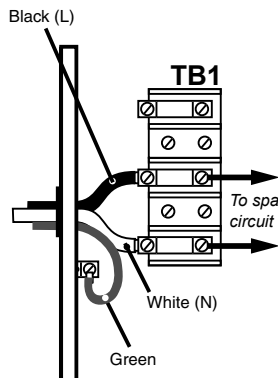
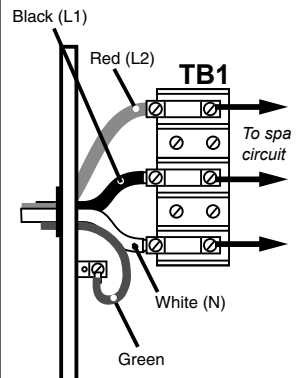

Illustration 4D:
Alternate 4-wire, 240/120 VAC
connection for Caprio, Tango,
Solo, and Lagunas models.

Hard wired connections only.



POWER SUPPLY REQUIREMENTS

Sundance Altamar, Cameo, Capri, Marin, and Optima Models

Important: the dealer must perform minor circuit board modifications when either models' alternate electrical configuration is used. To avoid damage to the hot tub, do not activate power until circuit board modifications have been made. We recommend Square-D or Cutler Hammer Breakers.

Factory 3-Wire Electrical Configuration

- Required Voltage: 240 VAC (2 Hots, 1 Ground); See diagram page 11.
- Required GFCI Breaker: 50 Amp Dual-pole (Hard Wired Only)
- Number of Wires: Three - Copper Only (Red, Black, Green)*
- Max Spa Current Draw: 40 Amps

*In 50A configuration, the heater on two-pump models **will not operate** while both jets pumps are running in high speed (see alternate configurations below.) Note: pump 2 runs only in high speed.*

Alternate 3-Wire Electrical Configuration #1

- Required Voltage: 240 VAC (2 Hots, 1 Ground); See diagram page 11.
- Required GFCI Breaker: 30 Amp Dual-pole (Hard Wired Only)
- Number of Wires: Three - Copper Only (Red, Black, Green)*
- Max Spa Current Draw: 24 Amps

*If the household's electrical service does not have the full 240V/50A power available, the hot tub may be connected to 240V/30A service if a minor circuit board modification is performed by the dealer. In this configuration, the heater will yield the same rapid temperature increase as in 50A operation but **will not operate** while either jets pump is running in high speed or when the air blower is running. Note: pump 2 runs only in high speed.*

Alternate 3-Wire Electrical Configuration #2

- Required Voltage: 240 VAC (2 Hots, 1 Ground); See diagram page 11.
- Required GFCI Breaker: 60 Amp Dual-pole (Hard Wired Only)
- Number of Wires: Three - Copper Only (Red, Black, Green)*
- Max Spa Current Draw: 48 Amps

*If the household's electrical service does not have the full 240V/60A power available, and the hot tub is a 2-pump model, the hot tub may be connected to 240V/60A service if a minor circuit board modification is performed by the dealer. In this configuration, the heater **will operate** while both jets pumps are running in high-speed. This may be preferable for owners of hot tubs in cold climates because it will help the hot tub maintain water temperature during use.*

**All models: wire size must meet NEC recommendations and is determined by maximum current draw and length of run.*

POWER SUPPLY REQUIREMENTS

Sundance Maxxus Models

Important: the dealer must perform minor circuit board modifications when either models' alternate electrical configuration is used. To avoid damage to the hot tub, do not activate power until circuit board modifications have been made. We recommend Square-D or Cutler Hammer Breakers.

Factory 3-Wire Electrical Configuration

- Required Voltage: 240 VAC (2 Hots, 1 Ground); See diagram page 11.
- Required GFCI Breaker: 60 Amp Dual-pole (Hard Wired Only)
- Number of Wires: Three - Copper Only (Red, Black, Green)*
- Max Spa Current Draw: 48 Amps

*If the household's electrical service does not have 240V/60A power available, the hot tub may be connected to 240V/50A service if a minor circuit board modification is performed by the dealer. In the 60A configuration, the heater **will operate** while any two jets pumps are running in high-speed. This may be preferable for owners of hot tubs in cold climates because it will help the hot tub maintain water temperature during use.*

Alternate 3-Wire Electrical Configuration #1

- Required Voltage: 240 VAC (2 Hots, 1 Ground); See diagram page 11.
- Required GFCI Breaker: 40 Amp Dual-pole (Hard Wired Only)
- Number of Wires: Three - Copper Only (Red, Black, Green)*
- Max Spa Current Draw: 32 Amps

*If the household's electrical service does not have the full 240V/50A power available, the hot tub may be connected to 240V/40A service if a minor circuit board modification is performed by the dealer. In this configuration, the heater will yield the same rapid temperature increase as in 50A operation but **will not operate** while either jets pump is running in high speed. Note: jet pumps 2 and 3 run only in high speed.*

Alternate 3-Wire Electrical Configuration #2

- Required Voltage: 240 VAC (2 Hots, 1 Ground); See diagram page 11.
- Required GFCI Breaker: 50 Amp Dual-pole (Hard Wired Only)
- Number of Wires: Three - Copper Only (Red, Black, Green)*
- Max Spa Current Draw: 40 Amps

*If the household's electrical service does not have the full 240V/60A power available, the hot tub may be connected to 240V/50A service if a minor circuit board modification is performed by the dealer. In this configuration, the heater will yield the same rapid temperature increase as in 60A operation but **will not operate** while two jets pumps are running in high speed. Note: jet pumps 2 and 3 run only in high speed.*

**All models: wire size must meet NEC recommendations and is determined by maximum current draw and length of run.*

POWER SUPPLY REQUIREMENTS

Sundance Caprio, Tango, and Solo Models

(See Page 21 for Caprio ST Models)

Important: the dealer must perform minor circuit board modifications when either models' alternate electrical configuration is used. To avoid damage to the hot tub, do not activate power until circuit board modifications have been made. We recommend Square-D or Cutler Hammer Breakers.

Factory 3-Wire Electrical Configuration

- Required Voltage: 120 VAC (1 Hot, 1 Neutral, 1 Ground); See diagram page 12.
- Required GFCI Breaker: 15 Amp Single-pole GFCI Cord (Supplied with Hot Tub)*
- Number of Wires: Three - Copper Only (Black, White, Green)*
- Max Spa Current Draw: 12 Amps

*In 15A configuration, the heater **will not operate** while the jets pump is running in high-speed. The heater will operate at 1kW. *The hot tub must be located no more than 10 feet from a dedicated grounded, grounding type electrical outlet so that the supplied power cord can be plugged directly into it. DO NOT USE AN EXTENSION CORD. If hot tub is more than 10 feet from an outlet it must be hard wired to a 15A single-pole GFCI breaker (purchased separately).*

Alternate 4-Wire Electrical Configuration #1

- Required Voltage: 240 VAC (2 Hots, 1 Neutral, 1 Ground); See diagram page 13.
- Required GFCI Breaker: 30 Amp Dual-pole (Hard Wired Only)
- Number of Wires: Four - Copper Only (Red, Black, White, Green)*
- Max Spa Current Draw: 21 Amps

*If the household's electrical service does not have the full 240V/40A power available, the hot tub may be connected to 240V/30A service if a minor circuit board modification is performed by the dealer. In this configuration, the heater will yield the same rapid temperature increase as in 40A operation but **will not operate** while the jets pump is running in high speed. The heater operates at 4kW in this configuration.*

Alternate 4-Wire Electrical Configuration #2

- Required Voltage: 240 VAC (2 Hots, 1 Neutral, 1 Ground); See diagram page 13.
- Required GFCI Breaker: 40 Amp Dual-pole (Hard Wired Only)
- Number of Wires: Four - Copper Only (Red, Black, White, Green)*
- Max Spa Current Draw: 30 Amps

*In the 40A configuration, the heater **will operate** while the jets pump is running in high speed. This may be preferable for owners of hot tubs in cold climates because it will help the hot tub maintain water temperature during use. The heater operates at 4kW in this configuration.*

*All models: wire size must meet NEC recommendations and is determined by maximum current draw and length of run.

POWER SUPPLY REQUIREMENTS

Sundance Caprio ST Models

(See Page 20 for Standard Caprio Models)

Important: the dealer must perform minor circuit board modifications when either models' alternate electrical configuration is used. To avoid damage to the hot tub, do not activate power until circuit board modifications have been made. We recommend Square-D or Cutler Hammer Breakers.

Factory 3-Wire Electrical Configuration

- Required Voltage: 240 VAC (2 Hots, 1 Ground); See diagram page 11.
- Required GFCI Breaker: 40 Amp Dual-pole (Hard Wired Only)
- Number of Wires: Three - Copper Only (Red, Black, Green)*
- Max Spa Current Draw: 30 Amps

*In 40A configuration, the heater **will operate** while the jets pump is running in high-speed.*

Alternate 3-Wire Electrical Configuration #1

- Required Voltage: 240 VAC (2 Hots, 1 Ground); See diagram page 11.
- Required GFCI Breaker: 25 Amp Dual-pole (Hard Wired Only)
- Number of Wires: Three - Copper Only (Red, Black, Green)*
- Max Spa Current Draw: 20 Amps

*If the household's electrical service does not have the full 240V/40A power available, the hot tub may be connected to 240V/25A service if a minor circuit board modification is performed by the dealer. In this configuration, the heater will yield the same rapid temperature increase as in 40A operation but **will not operate** while the jets pump is running in high speed.*

**All models: wire size must meet NEC recommendations and is determined by maximum current draw and length of run.*

POWER SUPPLY REQUIREMENTS

Sweetwater Lagunas Models

Important: the dealer must perform minor circuit board modifications when either models' alternate electrical configuration is used. To avoid damage to the hot tub, do not activate power until circuit board modifications have been made. We recommend Square-D or Cutler Hammer Breakers.

Factory 3-Wire Electrical Configuration

- Required Voltage: 120 VAC (1 Hot, 1 Neutral, 1 Ground); See diagram page 12.
- Required GFCI Breaker: 15 Amp Single-pole GFCI Cord (Supplied with Hot Tub)*
- Number of Wires: Three - Copper Only (Black, White, Green)*
- Max Spa Current Draw: 12 Amps

*In 15A configuration, the heater **will not operate** while the jets pump is running in high-speed. The heater will operate at 1kW. *The hot tub must be located no more than 10 feet from a dedicated grounded, grounding type electrical outlet so that the supplied power cord can be plugged directly into it. DO NOT USE AN EXTENSION CORD. If hot tub is more than 10 feet from an outlet it must be hard wired to a 15A single-pole GFCI breaker (purchased separately).*

Alternate 4-Wire Electrical Configuration #1

- Required Voltage: 240 VAC (2 Hots, 1 Neutral, 1 Ground); See diagram page 13.
- Required GFCI Breaker: 30 Amp Dual-pole (Hard Wired Only)
- Number of Wires: Four - Copper Only (Red, Black, White, Green)*
- Max Spa Current Draw: 21 Amps

*If the household's electrical service does not have the full 240V/40A power available, the hot tub may be connected to 240V/30A service if a minor circuit board modification is performed by the dealer. In this configuration, the heater will yield the same rapid temperature increase as in 40A operation but **will not operate** while the jets pump is running in high speed. The heater operates at 4kW in this configuration.*

Alternate 4-Wire Electrical Configuration #2

- Required Voltage: 240 VAC (2 Hots, 1 Neutral, 1 Ground); See diagram page 13.
- Required GFCI Breaker: 40 Amp Dual-pole (Hard Wired Only)
- Number of Wires: Four - Copper Only (Red, Black, White, Green)*
- Max Spa Current Draw: 30 Amps

*In the 40A configuration, the heater **will operate** while the jets pump is running in high speed. This may be preferable for owners of hot tubs in cold climates because it will help the hot tub maintain water temperature during use. The heater operates at 4kW in this configuration.*

**All models: wire size must meet NEC recommendations and is determined by maximum current draw and length of run.*

POWER SUPPLY REQUIREMENTS

Sweetwater Bahia, Cayman, and Palermo Models

Important: the dealer must perform minor circuit board modifications when either models' alternate electrical configuration is used. To avoid damage to the hot tub, do not activate power until circuit board modifications have been made. We recommend Square-D or Cutler Hammer Breakers.

Factory 3-Wire Electrical Configuration

- Required Voltage: 240 VAC (2 Hots, 1 Ground); See diagram page 11.
- Required GFCI Breaker: 50 Amp Dual-pole (Hard Wired Only)*
- Number of Wires: Three - Copper Only (Red, Black, Green)*
- Max Spa Current Draw: Palermo & Bahia Models= 36 Amps, Cayman Models= 34 Amps

Palermo & Bahia 2-Pump Models: In 50A configuration the heater **will not operate** while both jets pumps are running in high speed. **Cayman 1-Pump Models:** In 50A configuration the heater **will operate** when the jets pump is running in high speed.

Alternate 3-Wire Electrical Configuration #1

- Required Voltage: 240 VAC (2 Hots, 1 Ground); See diagram page 11.
- Required GFCI Breaker: 30 Amp Dual-pole (Hard Wired Only)
- Number of Wires: Three - Copper Only (Red, Black, Green)*
- Max Spa Current Draw: 24 Amps

*If the household's electrical service does not have the full 240V/50A power available, the hot tub may be connected to 240V/30A service if a minor circuit board modification is performed by the dealer. In this configuration, the heater will yield the same rapid temperature increase as in 50A operation but **will not operate** while either jets pump is running in high speed.*

Alternate 3-Wire Electrical Configuration #2 (Palermo & Bahia Models Only)

- Required Voltage: 240 VAC (2 Hots, 1 Ground); See diagram page 11
- Required GFCI Breaker: 60 Amp Dual-pole (Hard Wired Only)
- Number of Wires: Three - Copper Only (Red, Black, Green)*
- Max Spa Current Draw: 43 Amps

*In 60A configuration, the heater **will operate** while both jets pump are running in high speed. This may be preferable for owners of hot tubs in cold climates because it will help the hot tub maintain water temperature during use.*

**All models: wire size must meet NEC recommendations and is determined by maximum current draw and length of run.*

HOT TUB TECHNICAL SPECIFICATIONS

	Overall Width (Short Side)	Overall Length (Long Side)	Overall Height	Overall Width (Short Side cm)	Overall Length (Long Side cm)	Overall Height (cm)	Filled* Weight (lbs)	Filled* Weight (kg)	Minimum Pad Thicknes
Sundance 850 Series Spas									
Maxxus (wood skirt)	7'8"	9'4"	3'3.5"	234	284	100	5800	2630	4"
Maxxus (synthetic skirt)	7'6"	9'2"	3'3.5"	229	279	100	5800	2630	4"
Optima (wood skirt)	7'7"	7'7"	3'1.5"	231	231	95	4900	2223	4"
Optima (synthetic skirt)	7'5"	7'5"	3'1.5"	226	226	95	4900	2223	4"
Cameo (wood skirt)	7'7"	7'7"	3'1.5"	231	231	95	4586	2080	4"
Cameo (synthetic skirt)	7'5"	7'5"	3'1.5"	226	226	95	4586	2080	4"
Altamar (wood skirt)	6'11"	7'4"	3'1.5"	211	223	95	4032	1829	4"
Altamar (synthetic skirt)	6'9"	7'2"	3'1.5"	206	218	95	4032	1829	4"
Marin (wood skirt)	6'5"	7'6"	2'9"	196	229	84	3360	1524	4"
Marin (synthetic skirt)	6'3"	7'4"	2'9"	191	224	84	3360	1524	4"
Capri (wood skirt)	5'9"	7'	2'6.5"	175	213	77	2346	1064	4"
Capri (synthetic skirt)	5'7"	6'10"	2'6.5"	170	208	77	2346	1064	4"
Sundance Portofino Series Spas									
Caprio/Caprio ST (wood)	6'7"	7'4"	2'9"	201	224	84	3543	1607	4"
Caprio/Caprio ST (Syn.)	6'5"	7'2"	2'9"	196	218	84	3543	1607	4"
Tango (wood skirt)	5'	6'7"	2'6.5"	153	201	77	2026	919	4"
Tango (synthetic skirt)	4'10"	6'5"	2'6.5"	147	196	77	2026	919	4"
Solo (wood skirt)	4'	5'11"	2'5"	122	180	74	1238	562	4"
Solo (synthetic skirt)	4'	5'11"	2'5"	122	180	74	1238	562	4"
Sweetwater Series Spas									
Palermo (synthetic only)	7'6"	7'6"	3'	229	229	91	4189	1900	4"
Bahia (synthetic only)	7'4"	7'4"	3'	224	224	91	3852	1747	4"
Cayman (synthetic only)	7'	7'	3'	213	213	91	3562	1616	4"
Lagunas (synthetic only)	6'7"	7'4"	2'10"	201	224	86	3200	1452	4"

*Synthetic spa weights are listed. Spas with natural wood skirts are slightly lighter. The filled weights listed in this table will vary depending on water fill heights.

Specifications are for reference only and are subject to change without notice.



Notes:





Sundance[®] Spas

© 2003 SUNDANCE SPAS, INC. ALL RIGHTS RESERVED.
P/N 6530-073L, REVISION - B